



The mechanical design and control system of 9 DOF robotic crane

Michał Baczyński^{1*}, Janusz Baczyński^{2 †}

¹ *Technical University of Lodz, Institute of Automatic Control,
18/22 Stefanowskiego St., 90-924 Łódź, Poland*

² *University of Lodz, Faculty of Physics and Applied Computers Science,
149/153 Pomorska St., 90-236 Łódź, Poland*

Abstract

This work presents the status of running project (2007–2010). The new nine degrees of freedom cable driven robot has been developed. Main parts: the mechanical design of parallel manipulator and the heart of control system have been presented. The preliminary tests of the prototype application have been performed. As the final result of the project, a robotic cable driven crane will be developed, applicable in a wide range of practical commercial solutions.

1. Introduction

There are many activities which must be completed even if they are dangerous for people who supervise them. The main motivation for the presented paper is work that is done by sappers and services involved in examinations of suspicious parcels left in public places. Nowadays, people are aware of terrorism and its threats. That is why, all strange objects detected in the places like airports, railway or subway stations need human attendances and reactions. It is assumed that unattended parcels could be bombs and they must be safely removed and

*E-mail address: mbaczyn@p.lodz.pl

†E-mail address: bacz@uni.lodz.pl

destroyed. To reduce the possibility of people injuries in the case of explosions, robotic teleoperator systems are used. Instead of human, the robot approaches the suspicious object. The operator of the remote robot, separated from the danger workspace, guides the remote robot in real time. The teleoperator systems are especially useful for solving problems of remote transports and manipulations in dynamic environments where operations cannot be planned a priori. The baggage claim area of an airport is a good example of workspace where different kinds of obstacles appear, disappear and change the positions continuously in time [1, 2].

There are several known robotic solutions to approach the suspected object left in the baggage claim area of the evacuated airport. The teleoperated mobile robot can be used to examine the object, remove it and eventually destroy it. The most common moving strategies are:

- driving on wheels
- walking on legs

If we consider the evacuated airport or another public building, driving or walking robot could face problems when reaching the goal. The action could be very time consuming, especially in the environments full of obstacles. Sometimes the action could fail because luggage left in panic could make moving on the floor unavailable.

The presented solution bases on an idea of installing robotic cranes under the ceilings in the public halls that could be subjected to potential bomb attacks. Such cable driven manipulators are relatively inexpensive and are able to reach any goal from the air much more easily than mobile robots moving on the floor.

The conventional crane installed on the movable $X - Y$ platform forms a three degree of freedom robot, see Fig. 1.

Such a manipulator is not a sufficient solution because of several significant disadvantages. The main feature that must be eliminated is a non-rigid support of load. Moreover, three degrees of freedom are not enough to move and rotate the working point of robot [3].

The robotic crane, invented and developed at National Institute of Standards and Technology (NIST) called RoboCrane® is an example of crane that eliminates some of the negative features of conventional cranes [4, 5]. The RoboCrane® is an inverted Stewart Platform, that forms a moving platform. The robot is controlled in six degrees of freedom using six elastic metal cables on motor winches – see Fig. 2. Platform uses gravity to maintain tension in cables. The anchor points are mounted in fixed points under the ceiling. Six electric motor winches installed on the platform shorten and lengthen all cables independently. Over a limited range of motion and orientations the cable driven

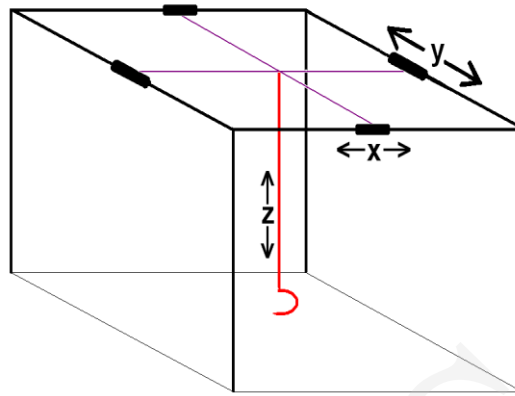

Fig. 1. Conventional crane installed on the $X - Y$ platform

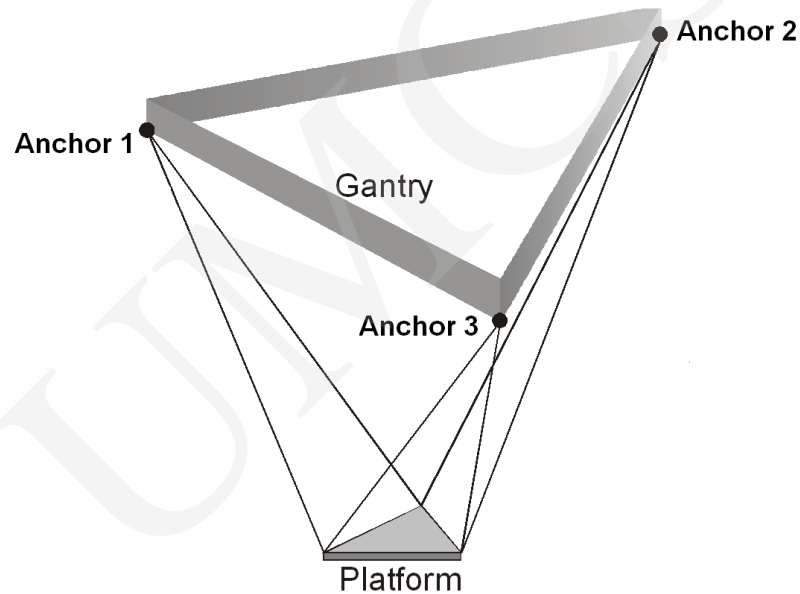

Fig. 2. Six DOF robotic crane - NIST RoboCrane®

platform can be controlled to be stiff and stable in six degrees of freedom. The RoboCrane® has been planned and designed to move and rotate heavy loads. To achieve this goal the platform is heavy itself, anchor points are fixed and thus the manoeuvrability is limited. Motivated by the NIST solution, we have proposed the nine degrees of freedom cable driven robot.

2. Mechanical design

The fundamental requirements for the platform have been defined [6, 7]:

- lightness to reduce the power of motors
- movable anchor points to extended manoeuvrability and changes the configuration

The top view of the proposed platform is presented in Fig. 3.

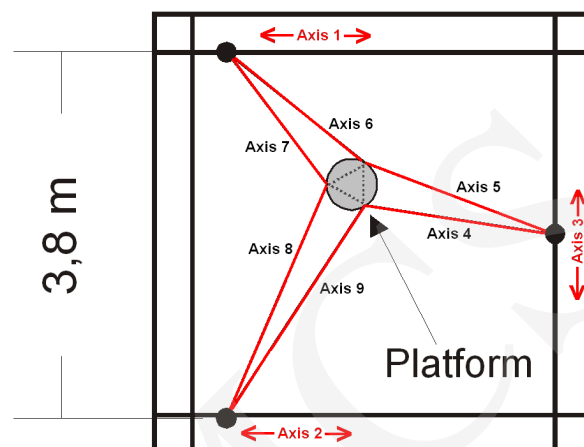

Fig. 3. The top view on the 9-DOF robot

The platform is hung under the ceiling with six metal cables. The independent change of the cable lengths causes the moves and rotations of the platform. Moreover, the anchor points are installed on the linear servomotors that make them movable. By installing the linear servomotors we have slightly extended the workspace and rotation range. Moreover, the region where the platform remains highly stable and stiff has been also extended. The linear servomotors extend the capabilities of platform and enable to achieve some poses with different configurations. These additional three degrees of freedom enable avoiding obstacles that are unavoidable in six degrees of freedom robot version.

The robot is controlled by nine motors: six winch motors that control the lengths of the cables and three motors that change the positions of anchor points. The platform of the described cable driven robot is light, since the six electric winch motors are installed out of the platform. Such a solution allows to use 75 Watt motors that control the lengths of cables and achieve the capability to safely maneuver – move and rotate a load of maximum 30 kilograms. In the anchor points the pulleys are mounted, thus motors are fixed not in the anchor points but on the floor level – see Fig. 4. All three anchor pulleys are movable – linear moves.

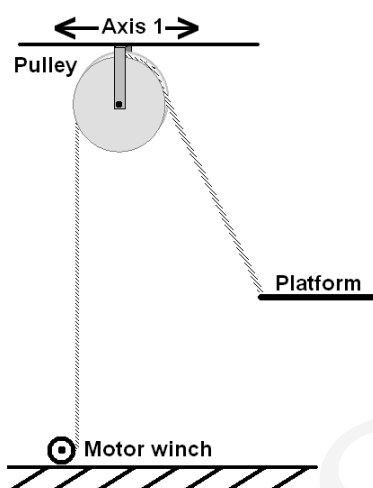

Fig. 4. The pulley in the anchor point

It is possible to change the positions of anchor points and keep the platform static. Changing the configuration enforces the use of nine motors simultaneously but it is possible in a relatively wide range of poses.

3. Control system

A few different concepts of hardware and software to control the robot were considered to obtain the best results: the system easy to develop and debug, responsible for normal operation. The decision was made to build the distributed system based on the main computer and real time axis-controllers. Fig. 5 presents the schematic architecture of the control system [8, 9, 10].

The general control algorithm is supervised by the PC computer working under the MS Windows operating system with installed comfortable rapid application development software tools. The external real time nine axis proportional-integral-derivative controllers are responsible for controlling servo loops of servomotors. Each of servomotors consists of 24V electric motor, high ratio gearbox and incremental encoder that gives the position feedback. It is worth noting that the encoder measures the position of motor, thus the achieved position measurement accuracy of the output gearbox shaft is very high.

The applied controllers are able to work in several modes. In our application they work in the most convenient mode – positioning mode with the symmetric trapezoidal velocity control. The controllers are interfaced with the personal computer by the RS-232 serial link. In fact, the controllers are linked to the USB computer port by the multiport USB-to-Serial converter. In this way, one USB port is used to control all nine servomotors. The system has to be

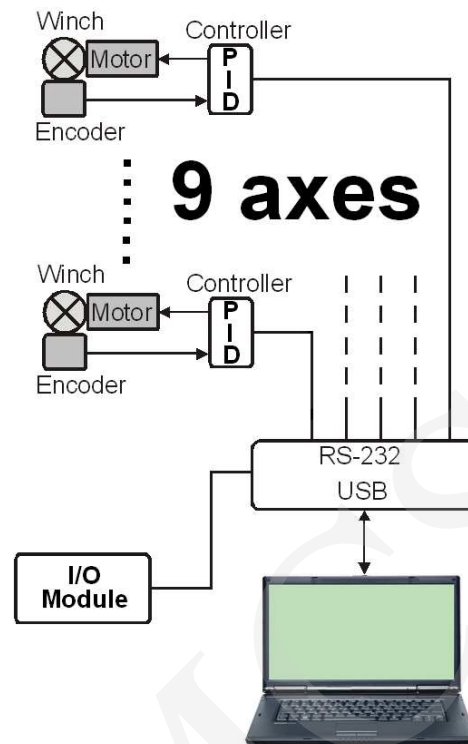

Fig. 5. The architecture of control system

initialized after powering on. The initialization process sets the proportional, integral and derivative values of PID controllers and finds home positions of all servomotors using optical home sensors. After the start-up procedure, during regular work the supervising computer sends commands to the slave axis controllers four times every second. The generic command includes the new desired absolute or incremental position, maximum velocity, acceleration and deceleration. The frequency of updating the main control loop is not high because the servo loop algorithm is processed on the external slave fast real time controllers. Such approach allows using a non real time operating system on the master computer and develop the graphical user interface.

One of the parts of control system is an universal multi input/output module. It is used to:

- read the states of the limit switches
- toggle the indicator LEDs on the front panel of the control system
- switch on/off ultrabright lights in the workspace to provide high quality visual feedback
- interface different kinds of sensors (future work).

The system is equipped with the Linksys Pan/Tilt/Zoom IP camera to provide visual feedback to the remote human operator. It sends the high-quality MPEG-4 compressed live video via the wireless network and gives flexible control remotely from a standard web browser application.

4. Inverse kinematic equations

The inverse kinematic equations function f_1 has been written. The function f_1 finds the lengths of cables for a given position and orientation of the platform and given positions of anchor points. In the described parallel robot the calculations of f_1 function are simple and unambiguous [11, 12]. The external Cartesian coordinate frame fixed to the ceiling has been defined and named ECCF. The given positions of anchor points:

$$P_1 = [x_{P1}, y_{P1}, z_{P1}]^T$$

$$P_2 = [x_{P2}, y_{P2}, z_{P2}]^T$$

$$P_3 = [x_{P3}, y_{P3}, z_{P3}]^T$$

are defined in the coordinate frame ECCF. The goal pose of the platform is given by the position and orientation vector

$$G = [x_G, y_G, z_G, A_G, B_G, C_G]^T$$

defined in the same coordinate frame ECCF. For the given goal pose G , it is possible to calculate the positions of points on the platform where cables are fixed

$$F_1 = [x_{F1}, y_{F1}, z_{F1}]^T$$

$$F_2 = [x_{F2}, y_{F2}, z_{F2}]^T$$

$$F_3 = [x_{F3}, y_{F3}, z_{F3}]^T$$

– see Fig. 6.

The relations between point G and points F_1, F_2, F_3 are simply pure geometric. The lengths of the cables $c_1 - c_6$ are calculated as magnitudes of difference of vectors as listed below:

$$c_1 = |F_1 - P_1|$$

$$c_2 = |F_2 - P_1|$$

$$c_3 = |F_1 - P_3|$$

$$c_4 = |F_3 - P_3|$$

$$c_5 = |F_2 - P_2|$$

$$c_6 = |F_3 - P_2|$$

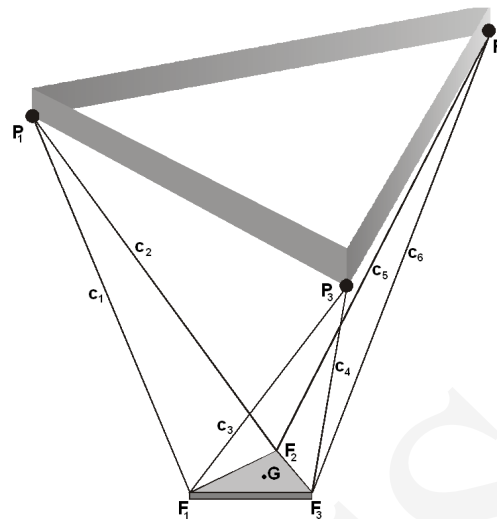

Fig. 6. The architecture of control system

5. Experimental tests – the current status of the project

The project is running, it is not completely finished but preliminary experimental tests have been performed [13]. The first phase of the tests is mechanical design analysis. The mechanical construction of steel and aluminium external frame is stiff enough for loads up to 30 kilograms. During the test with the mass of 40 kilograms, some minor deflections of frame have been noticed. As a result, the maximum permissible load has been estimated to 30 kilograms including the weight of platform. As the second test, we have studied the maximum accuracy of servomotors. The encoder fixed to the motor enables to reading the rotary position of the gearbox shaft with the accuracy of about $1/20000$ rev-1. The bottleneck of the whole drive structure is the gearbox and its backlash. We have finished the tests with the conviction that the linear accuracy is better than 0.5 mm, that is far enough for the designed application.

The tuning procedure of PID controllers has been experimental, based on several series of tests. It was not possible to check the correctness of the set values observing the gearbox shaft because of the backlash. As the output values for these tests, the positions of the encoders have been used. The optical sensors used as limit switches disable the rotations of servomotors only in the undesired directions. Still, it is possible to move the servo in the opposite direction to leave the limit region. Such solution allows to continue normal work of platform after reaching the limit switch without need to run a homing procedure. The tests using the algorithms to move the platform show that the update frequency of the master control loop is enough to achieve smooth

trajectory. Although only inverse kinematic equations have been solved, we have already started preparing methods to calculate position and orientation of the platform in the Cartesian coordinates frame based on the positions of nine servomotors. The wireless camera installed on the platform provides visual feedback with the sufficient resolution with the frame speed up to 30 frames per second. The built-in pan/tilt mechanism is easy to operate using the standard web browser. The camera is equipped with poor digital zoom only and it could be the reason for substitution of that device with a more advanced one.

6. Future work

The project has not been finished yet and still needs improvement and error fixing work. The control software will be rewritten, thus the graphical user interface has been prepared only for test purposes.



Fig. 7. The PHANTOM Omni haptic device

Moreover, we are going to implement advanced six degrees of freedom input device to enable human operator to guide the robot in as much intuitive way as it is possible. The velocity of platform is limited by the capabilities of servomotors. The operator will be informed that intentional movements are too fast by force feedback of the input apparatus. The product of SensAble Technologies - PHANTOM Omni haptic device will be applied, see Fig. 7. Moreover, we are in the process of preparing the new fast method of estimating the solution of direct kinematic problem for the cable driven robots.

7. Conclusions

The general idea of the running project has been presented. Most of the mechanical design and control system architecture has been successfully accomplished. The aim of this paper is to show the current status of the project and sketch the future work that will be carried. The tests show that a useful platform will be developed and it can be used in a wide range of practical applications.

Acknowledgments

The presented work has been financed by the Polish State research budget as development project R01 009 03 in the years 2007 - 2010.

References

- [1] Goertz R. C., *Fundamentals of General-Purpose Remote Manipulators*, Nucleonics, 10, 11 (1952) 36.
- [2] Goertz R. C., *Manipulators used for handling radioactive materials*, Human Factors in Technology, Chapter 27, Ed. E. M. Bennet, McGraw-Hill, 1963.
- [3] Albus J. S., Bostelman R. V., Proctor F. M., Shackelford W. P., Lytle A. M., *The Flying Carpet: A Tool to Improve Ship Repair Efficiency*, American Society of Naval Engineers Conference, September 10-12, 2002, Bremerton, WA, - September 01, 2002.
- [4] Bostelman R. V., Albus J. S., Dagalakakis N. G., Jacoff A., *Application of The NIST ROBOCRANE*, Robotics and Manufacturing 5 (1994).
- [5] Bostelman R. V., Albus J. S., Dagalakakis N. G., *A Robotic Crane System Utilizing the Stewart Platform Configuration*, Proc., ISRAM 1992, Conference, Santa Fe, N.M., Nov. 10-12, 1992.
- [6] Lung-Wen Tsai, *Robot Analysis: The Mechanics of Serial and Parallel Manipulators*, John Wiley & Sons, New York 1999.
- [7] Stone R. J., *Haptic Feedback: A Potted History, From Telepresence to Virtual Reality*, First International Workshop on Haptic Human-Computer Interaction. Glasgow, August 31-September 1, 2000.
- [8] Baczyński J., Baczyński M., *Simple Guidance Device For Remotely Controlling Teleoperators in Real Time*, IX IEEE International Conference on Methods and Models in Automation and Robotics, Międzyzdroje 2003.
- [9] Baczyński J., Baczyński M., *Simple Teleoperator System for Gamma Radiation Decontamination*, Proc. of the ISIE 2005 (IEEE International Symposium on Industrial Electronics), 2005, Dubrovnik Croatia, 20th - 23th June.
- [10] Baczyński J., Baczyński M., *Simple robotic system for detecting and marking gamma radiation impurities*, Proc. of the 11th IEEE International Conference on Methods and Models in Automation and Robotics - August 29, 2005 Międzyzdroje.
- [11] Fichter E. F., *A Stewart Platform-Based Manipulator: General Theory and Practical Construction*, Int. J. Robot. Res. 5(2) (1986) 157.

- [12] Postlethwaite I., Bartoszewicz A., *Application of nonlinear H-infinity control to the Tetra-bot robot manipulator*, Proceedings of Institution of Mechanical Engineers, Part I, 212(4) (1998).
- [13] Bosscher P. M., *Disturbance Robustness Measures and Wrench-Feasible Workspace Generation Techniques for Cable-Driven Robots*, Ph.D.Thesis, George W. Woodru® School of Mechanical Engineering Georgia Institute of Technology, November 2004.

UMCS