



Application of computer algebra systems (CAS) to formal expansion of exact Callen equations into the systems of algebraic equations

Adam Krzemieniowski, Grzegorz Wiatrowski*

Department of Solid State Physics, University of Łódź, 90-236 Łódź, Pomorska 149/153, Poland

Abstract

We present the application of computer algebra systems (CAS) to symbolic construction of algebraic equations describing different ordered as well as stochastic magnetic structures. We start with formal and exact, however non-tractable from the numerical point of view, Callen equations. Then, we apply the integral operator method (based on the integral representation of Dirac delta function) and use CAS to reformulate the related mathematical problem in terms of polynomial equations ready for numerical treatment. The complexity of the problem depends exponentially on coordination numbers of magnetic/nonmagnetic components, and by this, it makes the presented computer add approach the only possible method to treat complex multicomponent thin films and dilute multilayered structures. As two examples, we present the CAS add construction of related equations for binary alloys A_cB_{1-c} with structural disorder ($Z_A = 2$, $Z_B = 4$) and site-diluted thin film with $n = 8$ monatomic planes.

1. Introduction

In the early 60's the first computer algebra systems (CAS) have been used to treat some problems in astronomy and high energy physics in the up-to-date unusual symbolic way. As far as CAS permit us to handle an exact arithmetic and can treat non-assigned variables (*i.e.* variables in non-numerical but pure mathematical sense) the new possibilities opened in many fields of symbolic integration/differentiation problems, nonlinear/linear equations as well as polynomial systems and differential equations solving [1-5]. For almost fifty years many different specific systems have been designed (*e.g.* MuPad and Reduce), however sometimes discontinued like Axiom (by IBM and NAG) and Macsyma. Some of CAS are specialized for particular purposes like CoCoA in polynomial fields and Gröbner bases while others like mostly used Maple and

*Corresponding author: *e-mail*: wiatr@uni.lodz.pl

Mathematica (by Wolfram Co.) are still developing into new versions governing different fields of symbolic algebra [6-10].

Below, we show the application of CAS to symbolic construction of the systems of multi-variable polynomial equations describing the properties of stochastic magnetic systems. We start with the most general (exact) Callen equations (CE) derived in the frame of Ising model from the basic principles of statistical physics [12]. Unfortunately, the Callen formulae for local magnetizations m_i are not executable from the numerical point of view. This is because of the thermodynamic mean value over the nearest neighbourhood of the central i -site left to be performed later. Thus, we perform this averaging procedure by using the so called integral operator method in the lowest approximation level (first Matsudaira approximation) and obtain the expansion of the CE to a simpler polynomial form [13]. It should be stressed that we focus our present approach on the CAS application leaving the problem of numerical solutions aside considering them as the final test of the method correctness.

The particular advantage coming from the CAS application in symbolic derivation of specific long-term coefficients in CE is discussed below in the frame of two examples, namely the bulk binary alloy structure with arbitrary concentration of magnetic components and diluted magnetic thin films. The complexity of expressions grows up quickly with the coordination number and spin value of magnetic components. Moreover, the number of equations (means the number of coefficients) increases with the number of system components and atomic layers in the case of thin films, too. Thus, we finally conclude that correct symbolic expansion of CE performed without CAS is only possible in the simplest cases while the complex amorphous multicomponent film structures need the algorithmic and symbolic treatment with the add of CAS packages like Mathematica presented below.

2.1. Definition of the problem (here physical problem)

The problem of stochastic magnetic structure both infinite and with surface contribution (namely, thin films and multilayers) is one of the most important topics in the modern solid state physics and industrial applications [11]. The nowadays applications of such magnetic systems are commonly known, however, their proper description still needs further studies [14-16]. Below, we tend to derive equations describing properties of complex stochastic mixture of two or more magnetic and nonmagnetic components. The systems in question can form A_cB_{1-c} binary or diluted alloys (magnetic/nonmagnetic composition) in the form of bulk, thin film and multilayer structures with interface mixing included (see Fig. 1).

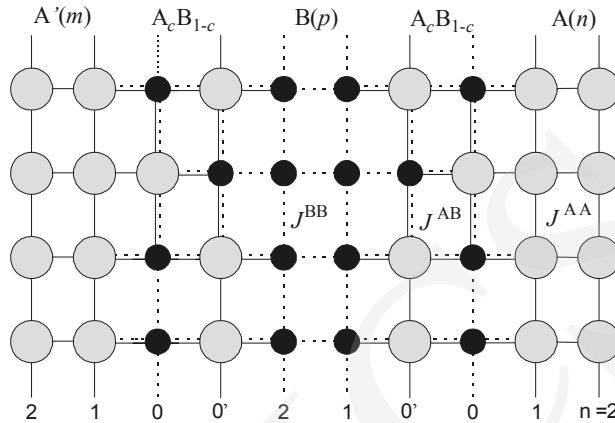

Fig. 1

As a starting point we consider the well known Callen equation (CE) [12]

$$\langle S_i^p \rangle_{T,c} = \langle F_p(E_p(i;T)) \rangle_{T,c}, \quad (1)$$

where $p = A, B, \dots$ (type of system component with a spin S^p), $\langle \dots \rangle_{T,c}$ means both thermodynamic and configuration averaging procedure, $E_p(i;T)$ stands for the magnetic energy related to the i -site of the structure occupied by p -component and

$$F_p(x) = \begin{cases} \tanh(x), & \text{dla } S^p = 1/2, \\ \sinh(x) / (\cosh(x) + \exp(-D/kT)) & \text{dla } S^p = 1, \text{ etc.} \end{cases} \quad (2)$$

The CE (1) is obtained from basic statistical principles and needs further mathematical treatment as far as its exact form is very general but unfortunately non-tractable one from a numerical point of view. In below, we introduce the integral operator method according to which CE transforms into the multi-variable polynomial equation after simple but tedious algebra. The latter becomes quick and very easy with the use of symbolic CAS methods.

2.2. Related mathematical model (the integral operator method)

The Dirac delta function and its integral representation let us to rewrite CE (1) as

$$\langle S_i^p \rangle_{T,c} = \int \langle \delta(x - E_p(i;T)) \rangle_{T,c} F_p(x) dx, \quad (3)$$

and further

$$\langle S_k^p \rangle_{T,c} = \int \Gamma \left\{ \langle \exp[-itE_p(k;T)] \rangle_{T,c} \right\} F_p(x) dx, \quad (4)$$

where we have used the Fourier transform $\Gamma\{\dots\}$ to simplify the CAS implementation discussed below.

3. CAS implementation

Equation (4) is still exact. We perform the averaging procedure in (4) neglecting all spin-correlations of next nearest neighbours in the considered crystallographic lattice. This is the first step of Matsudaira approximation in the frame of the cumulant method [13]. The present approach based on CAS treatment can be easily extended to introduce the next cumulants but this extension is out of the present scope and will be published elsewhere.

The exponential function in (4) is expanded into the products of powers related to the numbers of the nearest neighbours, means the coordination numbers Z_p ($p = A, B, \dots$) – for details we refer the reader to Ref. [15]. Here, we discuss CAS, in particular *Mathematica* package [9], implementation in two examples: (i) bulk binary alloy and (ii) diluted thin film.

Bulk binary alloy structure ($Z_A = 2$ and $Z_B = 4$)

To derive the equation for e.g. *B*-sublattice magnetisation mb we write

$$rmb = \text{Expand}[((CB \text{ Cos}[KBB \ t] - I \ mb \ \text{Sin}[KBB \ t] + CA)^ZB) * (CA \ \text{Cos}[KAB \ t] - I \ ma \ \text{Sin}[KAB \ t] + CB)^ZB]. \quad (5)$$

As a result we obtain the polynomial expression in the two partial magnetizations ma and mb

$$\begin{aligned} & \text{Cos}^4(KAB \ t) \ CA^8 + 4 \ CB \ \text{Cos}^3(KAB \ t) \ CA^7 \\ & + \dots + 72 \ CB \ ma^2 \ mb^2 \ \text{Cos}^2(KAB \ t) \ \text{Cos}(KBB \ t) \ \text{Sin}^2(KAB \ t) \ \text{Sin}^2(KBB \ t) \ CA^3 \quad (6) \\ & + \dots + 12 \ CB^5 ma^4 \ mb^2 \ \text{Cos}(KBB \ t) \ \text{Sin}^4(KAB \ t) \ \text{Sin}^2(KBB \ t) \ CA \\ & + \dots - 16 \ CB^6 \ ma \ mb \ \text{Cos}^3(KBB \ t) \ \text{Sin}(KAB \ t) \ \text{Sin}(KBB \ t), \end{aligned}$$

where coefficients depend on the component concentrations, C_A and C_B , while K_{AB} and K_{BB} are related to temperature $(k_B T)^{-1}$ and the exchange integrals J_{AB} , J_{BB} from Fig. 1, respectively. Next, we use the available *Fourier'Transform* package to perform the integral operator technique and *TrigReduce* command which allows for algebraic manipulation trigonometric functions as rational functions of exponentials:

$$rmb1 = \text{TrigReduce}[rmb], \quad (7)$$

$$\ll \text{Calculus}' \ \text{FourierTransform}' . \quad (8)$$

Let us find the easiest coefficient b_{43} in expression (6) standing by the term $ma^4 \ mb^3$:

$$wma4mb3 = \text{Coefficient}[rmb1, ma^4, mb^3], \quad (9)$$

$$fouma4mb3 = \text{FourierTransform}[wma4mb3, t, x], \quad (10)$$

$$b43 = \text{Integrate} [fouma4mb3 \ \text{Tanh}[x], \{x, -\text{Infinity}, \text{Infinity}\}]. \quad (11)$$

The result is

$$\begin{aligned}
 b_{43} = & (1/4) CA \operatorname{Tanh}[2 KAB - 3 KBB] - (1/16) CA \operatorname{Tanh}[4 KAB - 3 KBB] \\
 & + (1/8) CB \operatorname{Tanh}[2 (KAB - 2 KBB)] + (1/16) CB \operatorname{Tanh}[4 KAB - 2 KBB] \\
 & - (1/4) CB \operatorname{Tanh}[2 (KAB - KBB)] - (1/32) CB \operatorname{Tanh}[4 (KAB - KBB)] \\
 & - (3/4) CA \operatorname{Tanh}[2 KAB - KBB] + (3/16) CA \operatorname{Tanh}[4 KAB - KBB] \\
 & - (9/8) CA \operatorname{Tanh}[KBB] - (3/8) CB \operatorname{Tanh}[2 KBB] \\
 & + (3/8) CA \operatorname{Tanh}[3 KBB] + (3/16) CB \operatorname{Tanh}[4 KBB] \\
 & + (1/4) CB \operatorname{Tanh}[2 (KAB + KBB)] + (1/32) CB \operatorname{Tanh}[4 (KAB + KBB)] \\
 & + (3/4) CA \operatorname{Tanh}[2 KAB + KBB] - (1/16) CB \operatorname{Tanh}[2 (2 KAB + KBB)] \\
 & - (3/16) CA \operatorname{Tanh}[4 KAB + KBB] - (1/8) CB \operatorname{Tanh}[2 (KAB + 2 KBB)] \\
 & - (1/4) CA \operatorname{Tanh}[2 KAB + 3 KBB] + (1/16) CA \operatorname{Tanh}[4 KAB + 3 KBB]. \quad (12)
 \end{aligned}$$

The complete equation for mb in (5) but with all coefficients found as b_{43} in successive steps (9)-(12) is now ready for numerical treatment

$$\begin{aligned}
 eq_{mb} = mb = & CB (b_{43} ma^4 mb^3 + b_{41} ma^4 mb + b_{14} ma mb^4 \\
 & + b_{34} ma^3 mb^4 + b_{32} ma^3 mb^2 + b_{23} ma^2 mb^3 \\
 & + b_{21} ma^2 mb + b_{12} ma mb^2 + b_{30} ma^3 + b_{03} mb^3 \\
 & + b_{10} ma + b_{01} mb) \\
 & /. \{KAB \rightarrow a * KAA, KBB \rightarrow b * KAA\}. \quad (13)
 \end{aligned}$$

if solved together with the analogous polynomial equation eq_{ma} for ma related to A -component of binary alloy structure. In (13) we have used the algebraic rules, $KAB \rightarrow a * KAA$, $KBB \rightarrow b * KAA$, to introduce the dimensionless normalization of exchange parameters. Fig. 2 shows the complexity of successive coefficients b_{ij} in (13). Indeed, b_{43} contains the lowest number of components while the linear term coefficients, b_{10} and b_{01} , are the most complicated and contain up to 70 components. On the other hand, the linear term coefficients form the important equation giving the location $T_C(C_B)$ of phase transition [13-15]:

$$\begin{aligned}
 rtc = & (CA a_{10} - 1) (CB b_{01} - 1) = CA CB b_{10} a_{01} \\
 & /. \{KAB \rightarrow a * KAA, KBB \rightarrow b * KAA\}. \quad (14)
 \end{aligned}$$

In Fig. 3, we show the solution $T_C(C_B)$ of Eq. (14) for $J_{AB} = 0.5J_{AA}$ and $J_{BB} = b J_{AA}$.

In a similar way we treat below the CE in the case of homogeneous thin film with diluted simple cubic ($Z = 6$) structure [10-12].

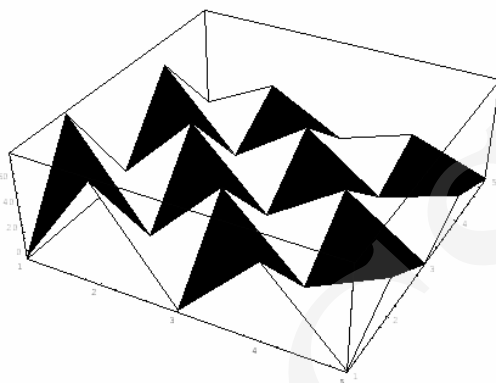

Fig. 2

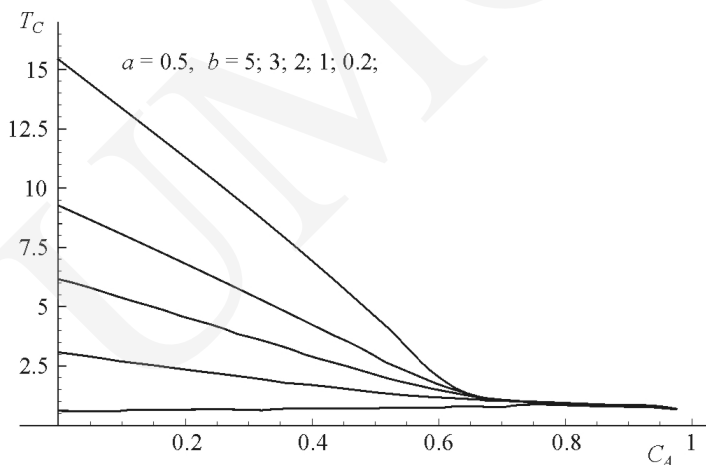

Fig. 3

Dilute magnetic thin film structure (film thickness $n = 8$ in monatomic planes)

In analogy to (5), we construct now the system of equations for $m[i]$ ($i = 1, 2, \dots, 8$):

$$rt[1]=Expand[((C1 \text{ Cos}[K t] - I m[1] \text{ Sin}[K t] + (1-C1))^4 (C1 \text{ Cos}[K t] - I m[2] \text{ Sin}[K t] + (1-C1))), \quad (15a)$$

$$Do[rt[i]=Expand[(C1 \text{ Cos}[K t] - I m[i-1] \text{ Sin}[K t] + (1-C1)) (C1 \text{ Cos}[K t] - I m[i] \text{ Sin}[K t] + (1-C1))], \quad (15b)$$

$$+ (1-C1)^4 (C1 \text{ Cos}[K t] - I m[i+1] \text{ Sin}[K t] + (1-C1))], \{i,2,7\},$$

$$rt[8]=Expand[((C1 \text{ Cos}[K t] - I m[8] \text{ Sin}[K t] + (1-C1))^4 (C1 \text{ Cos}[K t] - I m[7] \text{ Sin}[K t] + (1-C1))), \quad (15c)$$

where $C1$ denotes the concentration of magnetic component. The coefficients $aa[i, j, k, l]$ are found according to the procedure (9)-(11) for each plane ($i = 1, 2, \dots, 8$) and over all combinations (j, k, l) of nearest neighbours around the considered central i -site:

$$q[1] = m[1] == C1 \text{ Sum}[aa[1, 0, k, l] m[1]^k m[2]^l, \{k, 0, 4\}, \{l, 0, 1\}], \tag{16a}$$

$$Do[q[i] = m[i] == C1 \text{ Sum}[aa[i, j, k, l] m[i-1]^j m[i]^k m[i+1]^l, \{j, 0, 1\}, \{k, 0, 4\}, \{l, 0, 1\}], \{i, 2, 7\}], \tag{16b}$$

$$q[8] = m[8] == C1 \text{ Sum}[aa[8, j, k, 0] m[8]^k m[7]^j, \{k, 0, 4\}, \{j, 0, 1\}]. \tag{16c}$$

The numerical solutions (depth profiles of magnetization) are shown in Fig. 4 for $C1 = 0.4$ and the series of reduced temperatures $y = 0.4$ up to $y = 0.95$ where $y = T/T_C$.

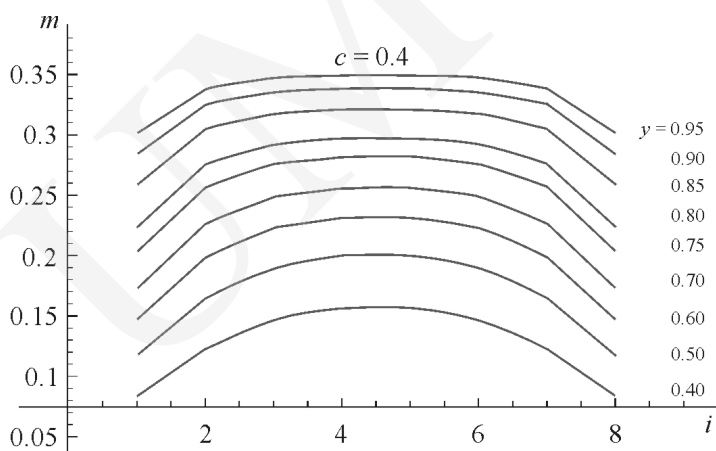

Fig. 4

Conclusions

The complexity of symbolic expansion of Callen equations in the Ising theory of multi-component magnetic structures requires the computer add packages like Mathematica or other computer algebra system handling non-numerical variables. The present paper shows a large simplification obtained by CAS application to formal reconstruction of the equations for mean values of magnetisation in both binary alloy and diluted thin film structures. In the frame of the mathematical formulation of the symbolic expansion we have used mainly the available Fourier' Transform package to perform the integral operator technique and the TrigReduce command which allows for algebraic manipulation trigonometric functions as rational functions of exponentials. The presented symbolic approach makes the unsolved treatment of CE in the

complex ternary thin film and the multilayer structures with high spin values and interface mixing possible. Moreover, the amorphous magnetic systems with the assumed distribution of structural parameters like partial coordination numbers can be also easily studied with similar CAS procedures. These are the main near future purposes where the present results will be applied, soon.

References

- [1] <http://www.mupad.de>
- [2] MacCallum M., Wright F., *Algebraic Computing with Reduce*, Clarendon Press, Oxford, (1991).
- [3] Rayna G., *REDUCE. Software for Algebraic Computation*, Springer Verlag, New York, (1987).
- [4] Jenks R.D., Sutor R.S., *Axiom. The Scientific Computation System*, Springer Verlag, New York, (1992).
- [5] <http://cocoa.dima.unige.it>
- [6] Corless R.M., *Essential Maple*, Springer Verlag, New York, (1995).
- [7] Heck A., *Introduction to Maple*, Springer Verlag, New York, (1996).
- [8] <http://www.maplesoft.com>
- [9] Wolfram S., *Mathematica. A System for Doing Mathematics by Computer*, Addison-Wesley, Redwood City, CA, (1991).
- [10] <http://www.wolfram.com>
- [11] Hartmann U., *Magnetic multilayers and giant magnetoresistance – fundamental and industrial applications*, in: U. Hartmann (Ed.), Surface Series In Surface Science, Springer, Berlin, Heidelberg, 37 (2000) 7.
- [12] Callen H.B., *A note on Green functions and the Ising model*, Phys. Lett., 4 (1963) 161.
- [13] Matsudaira N., *Ising ferromagnets with random impurities*, J. Phys. Soc. Japan, 35 (1973) 1593.
- [14] Wiatrowski G., Warda K., Wojtczak L., Baldomir D., Pereiro M., Arias J.E., *Magnetisation depth profiles in bilayer systems with mixed-spin interfaces – a contribution to temperature dependent GMR-potentials*, Surf. Sci., 507-510C (2002) 515.
- [15] Wiatrowski G., *Some magnetic properties of thin films in a mixed-spin surface Ising model*, J. Magn. Magn. Mater., 136 (1994) 209.
- [16] Wiatrowski G., Krzemieniowski A., *The method of reduction of transfer matrix for modulate systems*, Annales UMCS Informatica AI, 3 (2005) 191.